

CAT50 & Straight Shank ER25 Collet Chucks

(Balanced to G2.5@15,000 RPM)

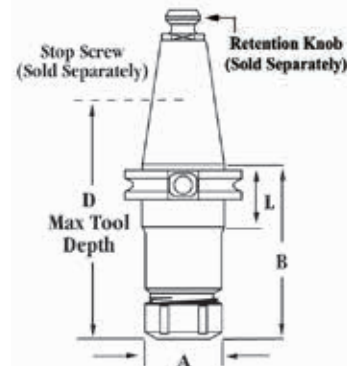

- Small diameter nose well-suited for working in close quarters
- Increased flexibility for milling, drilling, and reaming
- Flush precision collet nut, grips tool close to cutting edge for accuracy and rigidity
- Concentric to .0002" TIR puts tool precisely on spindle center line
- AT3 or better shank taper allows for accurate, rigid toolholder-to-spindle mount
- Wide range collets reduce collet and toolholder inventories
- Fully ground flange and V-groove is easy on tool changers for less spindle and changer maintenance
- Through spindle coolant standard
- [ER25 Collets found on pages 606-607.](#)



CAT50 ER25 Collet Chucks

Capacity	Taper	A	Gage Length (B)	D	L	Max. Nosepiece Torque	Part #
.040-.629	CAT50	1.64	4.00	3.50	1.38	42 ft lbs	RC5ER254000
.040-.629	CAT50	1.64	6.00	3.50	1.38	42 ft lbs	RC5ER256000

ER25 Straight Shank Collet Extension

A	B	D	L	Photo	Dimensions	Part #
1.64	7.5	1.00	5.5			RSSER25750

ER25 Parts & Accessories

Description	Photo	Dimensions	Part #
ER25 Replacement Nosepiece			RER25NPA
ER25 Collet Wrench†			RER25W
ER25 Stop Screw			RER25SS
ER25 Stop Screw Coolant Thru			RER25SSC

†Required for assembly.